

# **Installation / Operation / Maintenance**

## **Nuclestat® Linear Ionizer**

### **Models P-2001 and P-2001-I, and Combination Bar Model P-2001/4165**

#### **Please Observe the Following**

##### **NOTICE:**

Please review the information in this manual prior to operating the Nuclestat® in a work environment.

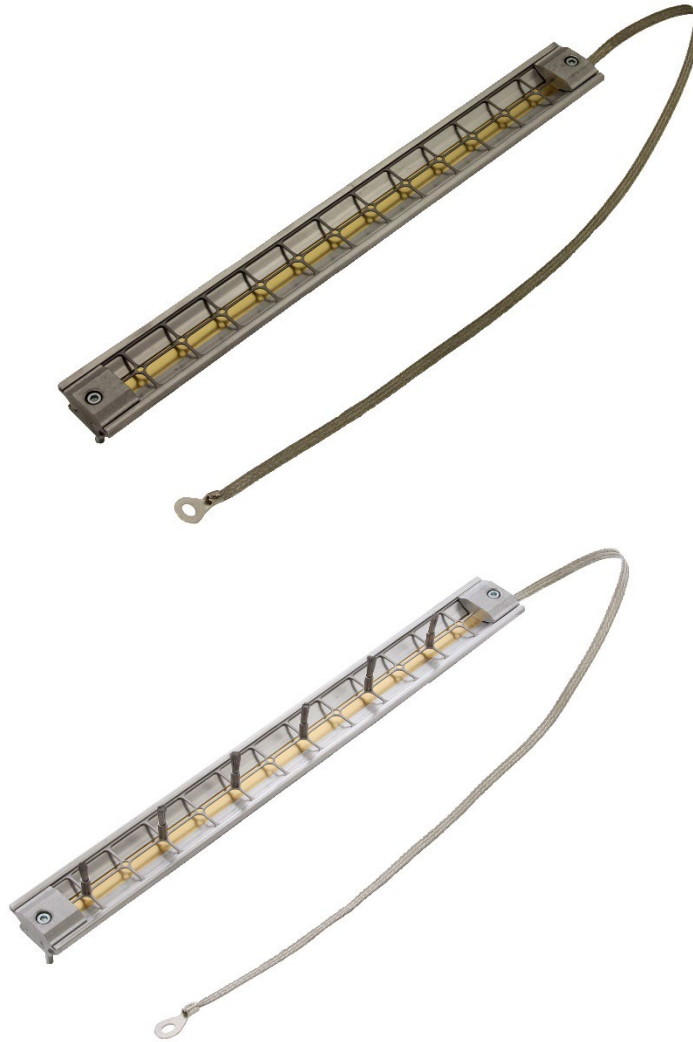

NRD, LLC / 2937 Alt Boulevard / Grand Island, NY 14072  
PHONE 716 773 7634 / FAX 716 773 7744 / EMAIL [sales@nrdlc.com](mailto:sales@nrdlc.com) / WEB [www.nrdlc.com](http://www.nrdlc.com)

NRD Asia Pte. Ltd  
PHONE +65 6679 1707 / EMAIL [sales@NRDAsia.com](mailto:sales@NRDAsia.com) / WEB [www.nrdlc.com](http://www.nrdlc.com)

Please keep this document in a convenient place to refer to as a guide

## Description

This family of ionizers neutralizes the high static charges developed in materials being processed by providing ionized air to them.

## Installation & Operation

1. Remove the protective cover shield by sliding it off either end.
2. Determine a mounting location that will satisfy the following requirements:
  - A) The ionizer will face the side of the material that is statically charged.
  - B) The ionizer will be positioned after the point where static is developed, e.g., after the last static generating roller or friction point.
  - C) The distance between the ionizer (i.e., Nuclestat® grid or Induction Bar brushes or points) and the charged material will be 2 approx.. 1-1/8”(3 cm).
  - D) No part of the ionizer will contact the charged material during normal process operations.
  - E) If the Model P-2001-I is to be installed, the processed material must pass by the Induction Brushes without contact.

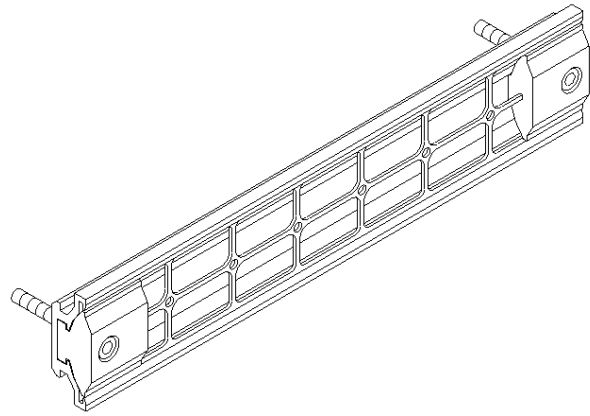

- F) If installing more than one ionizer for a single application, the ionizers will not be positioned directly opposite each other on both sides of the material being processed.
3. Mount the ionizer to a rigid structure in the selected location. Attachment hardware (two #8-32 socket head cap screws) is provided.
4. Ground the ionizer by attaching the eyelet at the free end of the grounding strap to ground potential. (Attachment hardware is not provided). Ensure that the process machinery is also grounded. Verify that the ionizer and machinery are grounded by having them checked by a qualified electrician.

**The ionizer is now ready for use.**

## Maintenance

- Maintenance is **not** required except that the Nuclestat® must be kept clean by blowing dry, filtered, compressed air over its surface.
- Calibration is **not** required.
- To ensure maximum static removal efficiency, the Nuclestat® must be replaced annually regardless of use. The replacement date is one year after the date manufactured (printed on each Nuclestat®). NRD will remind customers of the replacement date.



NRD, LLC / 2937 Alt Boulevard / Grand Island, NY 14072  
PHONE 716 773 7634 / FAX 716 773 7744 / EMAIL sales@nrdlc.com / WEB www.nrdllc.com

NRD Asia Pte. Ltd  
PHONE +65 6679 1707 / EMAIL sales@NRDAsia.com / WEB www.nrdllc.com

## Trouble Shooting Guide

Symptom	Probable Cause	Corrective Action
1. Static charges are not eliminated	Nuclestat® is out of date and needs replacement	Call NRD for a replacement Nuclestat®
	Dirt buildup on the Nuclestat®	Remove dirt using clean, dry, compressed air
	Nuclestat® or equipment is not properly grounded	Secure Nuclestat® or equipment to ground potential
2. Static charges are eliminated only on one side of the material being processed	Material is in contact with equipment or additional material layers	Freely suspend material being processed

**For additional assistance call NRD Customer Service toll-free at  
1-800-525-8076**

### Limited Warranty

NRD expressly warrants that for a period of one (1) year from the time of purchase, the item will be free of defects in material (parts) and workmanship (labor). Within the warranty period, the item will be tested, repaired, or replaced at discretion of NRD, free of charge. Any item under warranty should be shipped prepaid to the NRD factory. Call Customer Service at (716) 773-7634 for a Return Authorization number and shipping instructions. Include a copy of your original packing slip, invoice, or other proof of purchase date.

If the item is out of warranty, NRD LLC will quote repair charges necessary to bring your item up to factory standards.

### Warranty Exclusions

The forgoing express warranty is made in lieu of all other product warranties, expressed and implied, including merchantability and fitness for a particular purpose that is specifically disclaimed. The express warranty will not apply to defects or damage due to accidents, neglect, misuse, alterations, operator error, or failure to properly maintain, clean or repair products.

### Limit of Liability

The user shall determine the suitability of the product for their intended use, and the user assumes all risk and liability whatsoever in connection therein.



NRD, LLC / 2937 Alt Boulevard / Grand Island, NY 14072  
PHONE 716 773 7634 / FAX 716 773 7744 / EMAIL sales@nrdlc.com / WEB www.nrdllc.com

NRD Asia Pte. Ltd  
PHONE +65 6679 1707 / EMAIL sales@NRDAsia.com / WEB www.nrdllc.com