

## Installation / Operation / Maintenance

# ESD Workstation Kit Model 5021

### Introduction

The purpose of an ESD work surface is to aid in the prevention of damage to ESD sensitive components and assemblies from electrostatic discharge. An ESD work surface provides protection in the following two ways:

1. Providing a dissipative work surface area that will limit static electricity generation.
2. Removing the charge from a conductive object placed on the work surface. A dissipative work surface having a surface resistance of at least  $1 \times 10^6$ , but less than  $1 \times 10^9$  ohms is recommended by work surface standard ANSI/ESD S4.1. Dissipative materials minimize the generation of static charges, and will dissipate a charge slow, preventing a rapid electrostatic discharge. Dissipative materials are usually the preferred choice for bench top work surfaces.

### General Instructions and Guidelines

1. Allow the Workstation ESD mat to lay flat on a surface and ensure that it is flattened out from being rolled during shipment before using.
2. Connect the Workstation ESD mat common point ground to earth ground, or auxiliary ground point using the ground wire (black in color) provided. Refer to the diagram in Figure 1 and Figure 2 below.

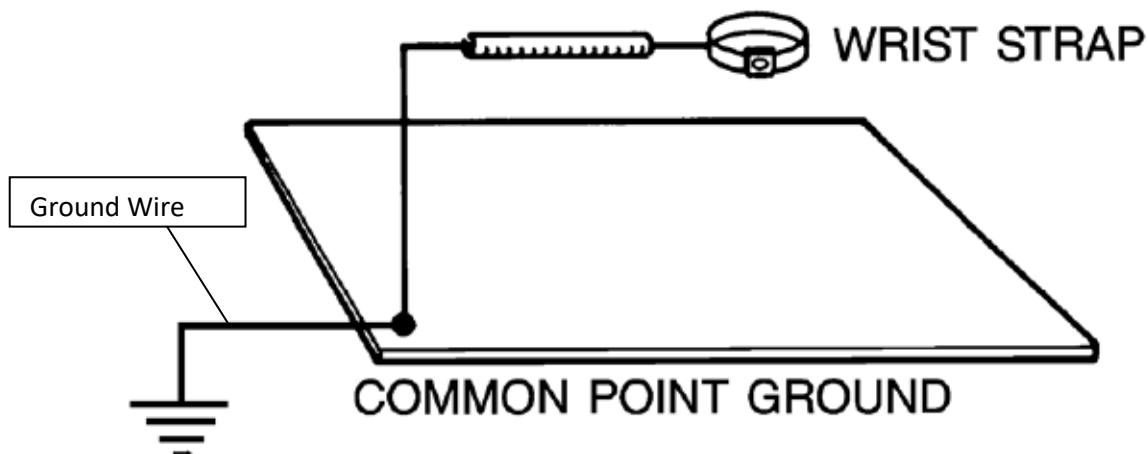

Figure 1: Connection of ESD Workstation Mat to the Common Ground and to the Wrist strap



NRD, LLC / 2937 Alt Boulevard / Grand Island, NY 14072  
PHONE 716 773 7634 / FAX 716 773 7744 / EMAIL [sales@nrdllc.com](mailto:sales@nrdllc.com) / WEB [www.nrdllc.com](http://www.nrdllc.com)

NRD Asia Pte. Ltd  
PHONE +65 6679 1707 / EMAIL [sales@NRDAsia.com](mailto:sales@NRDAsia.com) / WEB [www.nrdllc.com](http://www.nrdllc.com)

3. Connect the wrist strap banana plug to the common point ground banana jack on the mat (refer to Figure 2). This is recommended per the ESD standard for wrist straps S1.1.

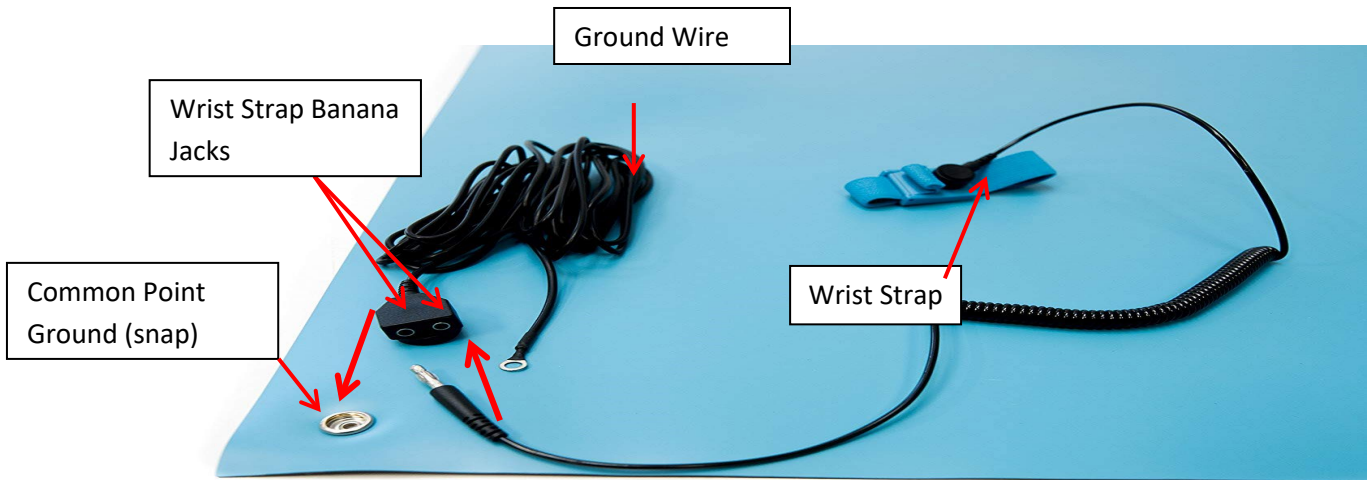

Figure 2: Connecting the common point ground and wrist strap to the ESD mat.



Figure 3: Connected Wire to the ESD Mat (for common grounding) and Wrist Strap

4. The mat ground wire must be tied to a suitable earth ground, auxiliary ground port, “green wire” equipment ground or common ground. Information on grounding can be found in ANSI/ESD 6.1.

Note: Common point grounds are designed to provide grounding for work surface mats, wrist straps, and other items.



NRD, LLC / 2937 Alt Boulevard / Grand Island, NY 14072  
PHONE 716 773 7634 / FAX 716 773 7744 / EMAIL [sales@nrdllc.com](mailto:sales@nrdllc.com) / WEB [www.nrdllc.com](http://www.nrdllc.com)

NRD Asia Pte. Ltd  
PHONE +65 6679 1707 / EMAIL [sales@NRDAsia.com](mailto:sales@NRDAsia.com) / WEB [www.nrdllc.com](http://www.nrdllc.com)

Note: All electrical outlets should be verified for proper wiring configuration, resistance or impedance and function when the mat is installed and periodically thereafter.

Note: Per ANSI/ESD S20.20, the ESD control program can in no way replace or supersede any requirements for personnel safety. Ground fault circuit interrupters (GFCI) and other safety protection should be considered wherever personnel might come into contact with electrical sources

## **Maintenance and Cleaning of ESD Mat**

For optimum performance, periodic cleaning is required.

1. For light duty cleaning of the ESD mat, just wipe the surface with a cloth or paper towel dampened with clean water, preferably deionized water (DI water).
2. For ESD mat with moderate to dirty surfaces, you may use a cleaner such as the 6001 Mat and Table Top Cleaner or other approved ESD mat cleaners.
3. Do not use cleaners with silicone as it leaves an insulated residue on surfaces and solvents such as 2-Butoxyethanol or Ethanolamine used in cleaners can dry out the material; both can prevent conductive or dissipative mats from functioning properly.
4. Do not use strong alcohol like 100% IPA (Isopropyl Alcohol) because it will slowly damage the surface of the ESD mat.

## **Maintenance of ESD Wrist Strap**

1. After a period of time, to ensure that the wrist strap is working properly, use a Wrist Strap Checker or meter per ESD TR53.
2. For proper operation, the wrist strap, especially the wrist band, must be kept clean. All wrist bands should be cleaned with a mild detergent on a periodic basis. Be sure that metallic expansion wrist bands are thoroughly dried to prevent corrosion.



**NRD, LLC** / 2937 Alt Boulevard / Grand Island, NY 14072  
**PHONE** 716 773 7634 / **FAX** 716 773 7744 / **EMAIL** sales@nrdllc.com / **WEB** [www.nrdllc.com](http://www.nrdllc.com)

**NRD Asia Pte. Ltd**  
**PHONE** +65 6679 1707 / **EMAIL** sales@NRDAsia.com / **WEB** [www.nrdllc.com](http://www.nrdllc.com)

### **Limited Warranty**

NRD expressly warrants that for a period of ninety (90) days from the time of purchase, the item will be free of defects in material (parts) and workmanship (labor). Within the warranty period, the item will be tested, repaired, or replaced at discretion of NRD, free of charge. Any item under warranty should be shipped prepaid to the NRD factory. Call Customer Service at (716) 773-7634 for a Return Authorization number and shipping instructions. Include a copy of your original packing slip, invoice, or other proof of purchase date.

If the item is out of warranty, NRD LLC will quote repair charges necessary to bring your item up to factory standards.

#### **DISCLAIMER:**

This serves as guideline only for NRD's ESD Workstation Kit, model 5021. This does not supersede other documentation about personnel safety. When used with Equipment or station that will be connected to main ground, ensure that proper grounding and other safety protection will be considered.

### **Warranty Exclusions**

The forgoing express warranty is made in lieu of all other product warranties, expressed and implied, including merchantability and fitness for a particular purpose that is specifically disclaimed. The express warranty will not apply to defects or damage due to accidents, neglect, misuse, alterations, operator error, or failure to properly maintain, clean or repair products.

### **Limit of Liability**

The user shall determine the suitability of the product for their intended use, and the user assumes all risk and liability whatsoever in connection therein.



**NRD, LLC** / 2937 Alt Boulevard / Grand Island, NY 14072  
**PHONE** 716 773 7634 / **FAX** 716 773 7744 / **EMAIL** sales@nrllc.com / **WEB** [www.nrllc.com](http://www.nrllc.com)

**NRD Asia Pte. Ltd**  
**PHONE** +65 6679 1707 / **EMAIL** sales@NRDasia.com / **WEB** www.nrllc.com